

1 2 3 4 5 6 7 8 9

F

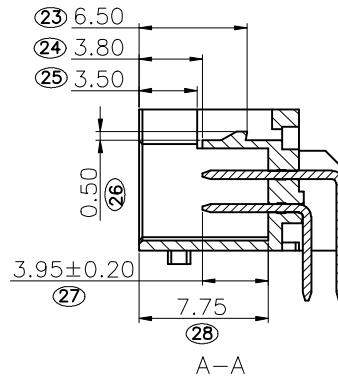
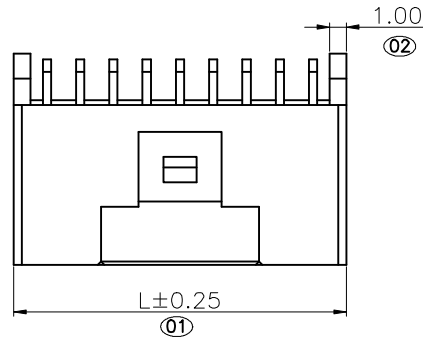

Specifications
 Voltage rating:250V AC/DC
 Current Rating:3Amp (AWG #22)
 Insulation Resistance:1000ΩMin.
 Dielectric Withstanding Voltage:800VAC
 Contact Resistance:20mΩMax.
 Operating Temperature:-25°C to +85°C
Materials
 Contact Material:Brass
 Insulator Material:
 Regular Thermoplastic: Only Suitable for
 Wave Soldering Process (Nylon 66).
 All materials must meet Greenconn
 requirement for environment protection.

E

D

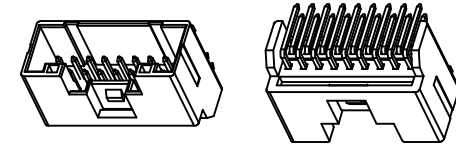
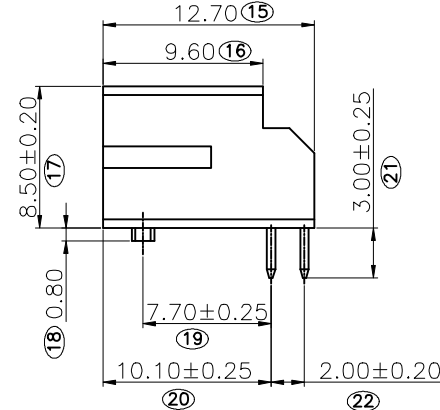
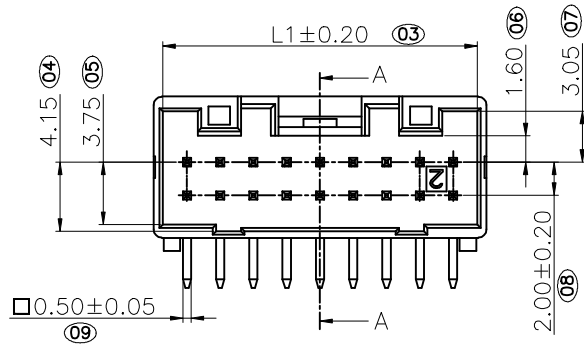

C

B

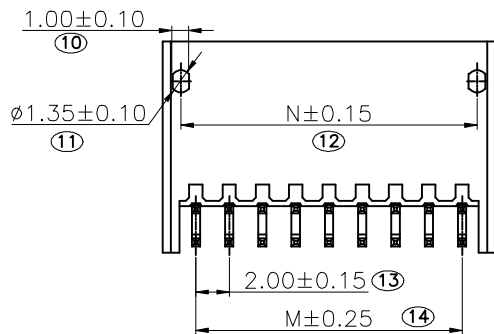

No. of circuits	Dimension Information			
	L	L1	M	N
2x4pin	10.00	8.90	6.00	7.80
2x5pin	12.00	10.90	8.00	9.80
2x6pin	14.00	12.90	10.00	11.80
2x7pin	16.00	14.90	12.00	13.80
2x8pin	18.00	16.90	14.00	15.80
2x9pin	20.00	18.90	16.00	17.80
2x10pin	22.00	20.90	18.00	19.80
2x20pin	42.00	40.90	38.00	39.80

Ordering Information

G WFB215 - XX XX B 001 W 4 B X
 No. Of Pins Per Row 04~20 Standard Plating 01=Tin Insulator Material W=PA66 Color 4=Naturer Contact Material A=Brass Standard Packing C=Tube

A



Website:www.greenconn.com
 E-mail:sales@greenconn.com

REV. C UNIT. mm SCALE. 5:4

3RD.ANG PROJ.

 PAGE. 1/4

GENERAL TOLERANCE

X.±5.0'	X.±0.30
.X'±3.0'	.X±0.25
.XX'±2.0'	.XX±0.15
.XXX'±1.0'	.XXX±0.10

DESIGNED:
 CHECKED:
 APPROVED:

DATE:
 DATE:
 DATE:

DWG. NO.

GWFB215-CB001

PART NO.

GWFB215-XXXXB001W4BX

TITLE.

PITCH 2.00mm Side
 Type WIRE TO BOARD
 CONNECTOR

1 2 3 4 5 6 7 8 9

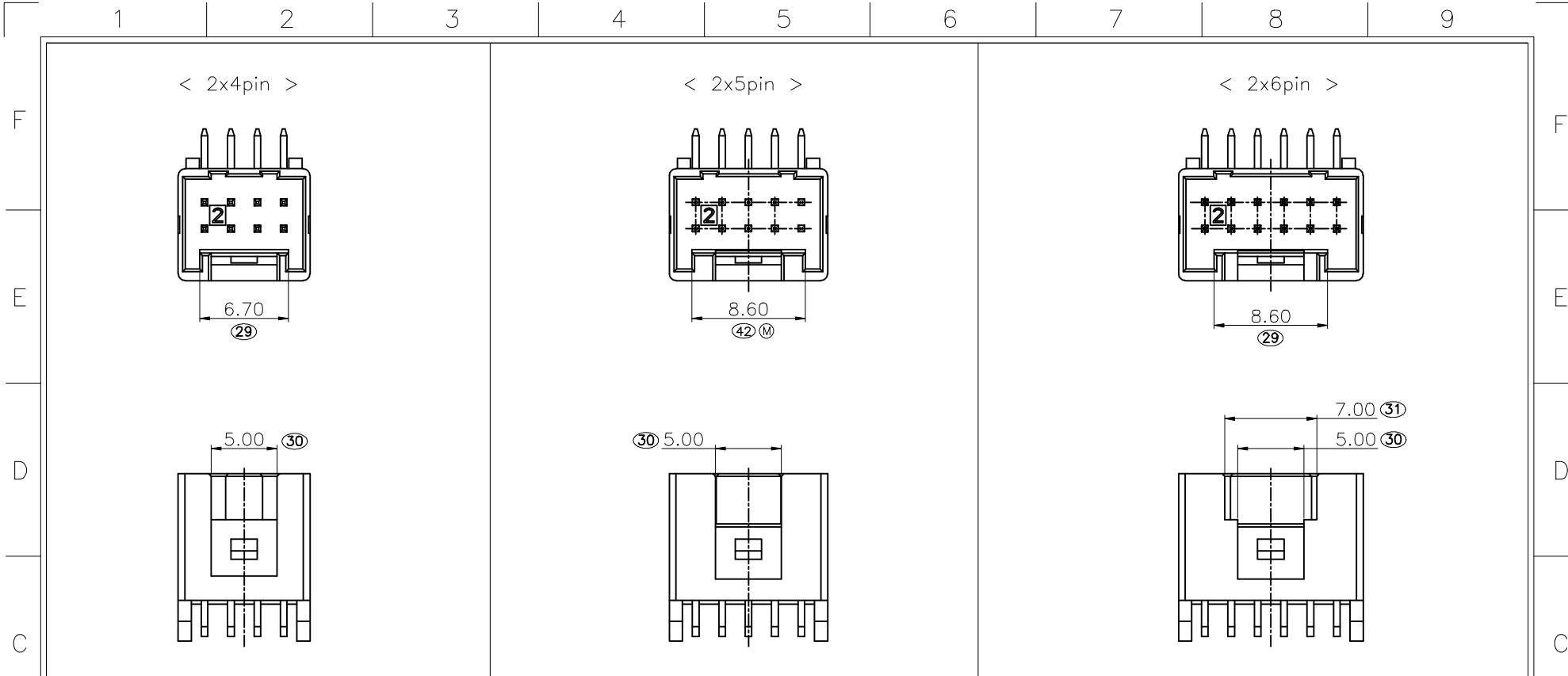

Blank area for additional notes or specifications.

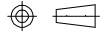
A	 Website: www.greenconn.com E-mail: sales@greenconn.com		3RD.ANG PROJ.  PAGE. 2/4	GENERAL TOLERANCE		DESIGNED: CHECKED: APPROVED:	DATE: DATE: DATE:	DWG. NO.	TITLE.
				X. ±3.0'	X. ±0.25			GWFB215-CB001	
				.X' ±2.0'	.X ±0.20			PART NO.	
				.XX' ±1.0'	.XX ±0.13			GWFB215-XXXXB001W4BX	
REV. C	UNIT. mm	SCALE. 5:4		.XXX' ±0.5'	.XXX ±0.08				

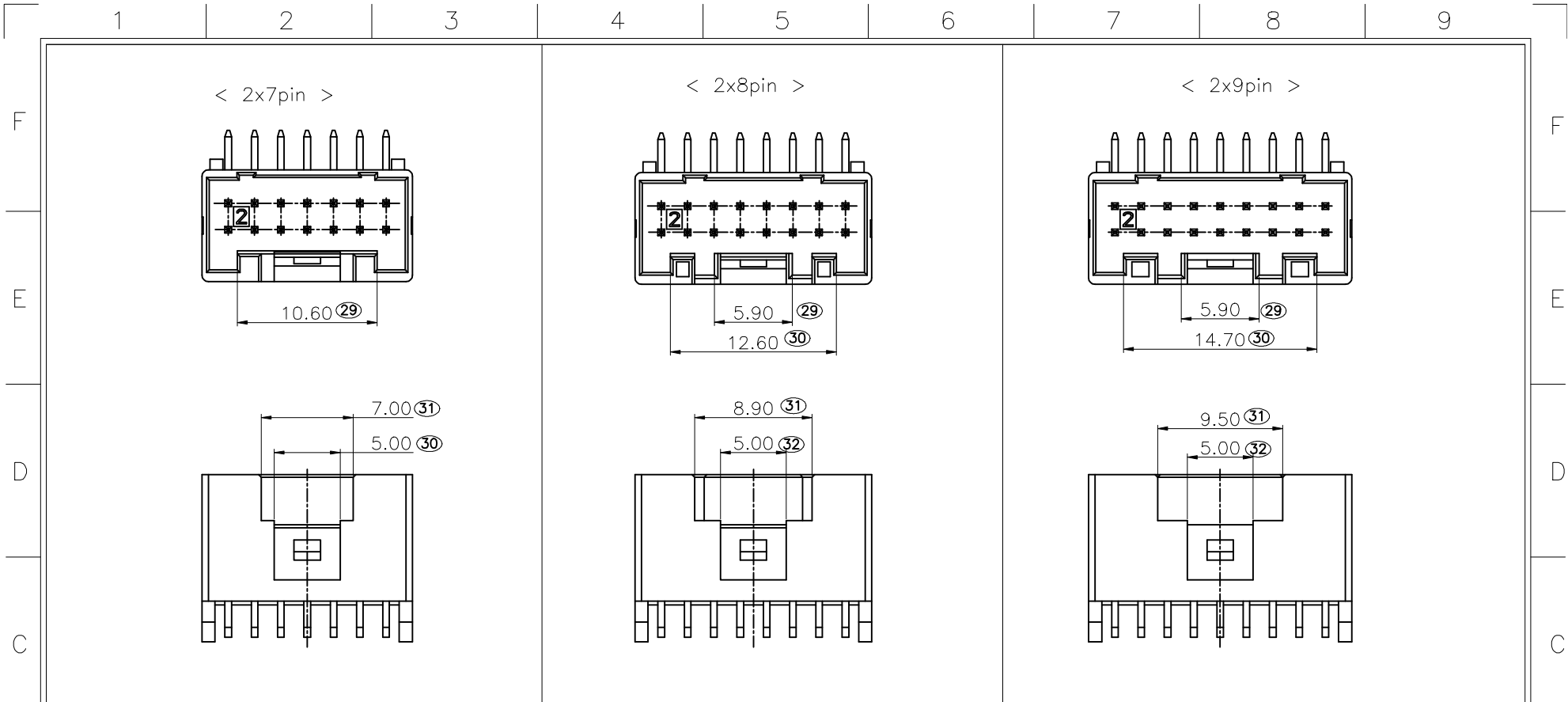

B

A			3RD.ANG PROJ. 	GENERAL TOLERANCE		DESIGNED:	DATE:	DWG. NO. GWFB215-CB001	TITLE. PITCH 2.00mm WIRE TO BOARD CONNECTOR
	Website: www.greenconn.com E-mail: sales@greenconn.com			X: ±3.0'	X: ±0.25				
	REV. C	UNIT. mm	SCALE. 5:4	PAGE. 3/4	.X' ±2.0'	.X ±0.20			
					.XX' ±1.0'	.XX ±0.13			
					.XXX' ±0.5'	.XXX ±0.08	APPROVED:	DATE:	

1 2 3 4 5 6 7 8 9

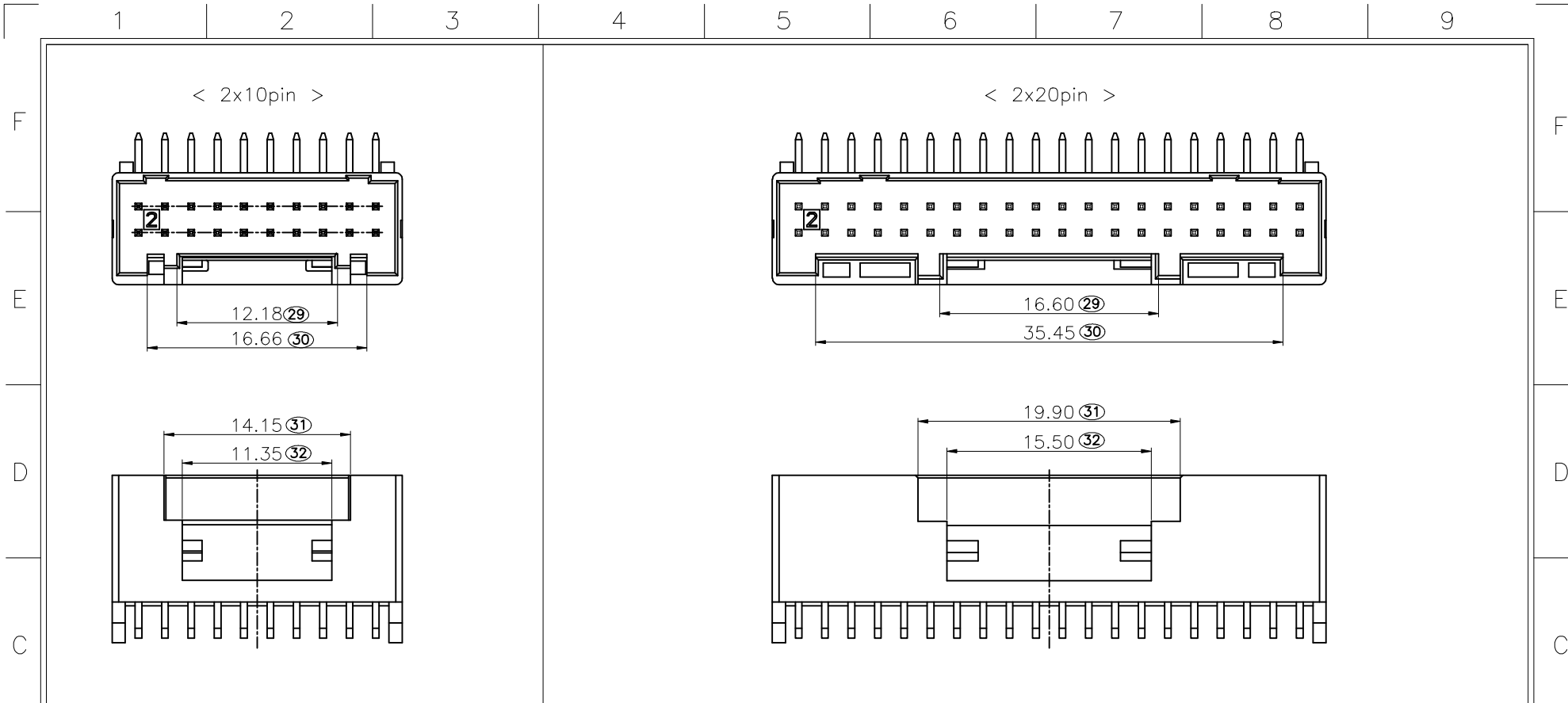

Greenconn
 Website: www.greenconn.com
 E-mail: sales@greenconn.com

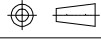
3RD.ANG
 PROJ.

 PAGE. 4/4

GENERAL TOLERANCE	
X.' ±3.0'	X. ±0.25
.X' ±2.0'	.X ±0.20
.XX' ±1.0'	.XX ±0.13
.XXX' ±0.5'	.XXX ±0.08

DESIGNED:
 CHECKED:
 APPROVED:

DATE:
 DATE:
 DATE:

DWG. NO.
 GWFB215-CB001
 PART NO.
 GWFB215-XXXXB001W4BX

TITLE.
 PITCH 2.00mm
 WIRE TO BOARD
 CONNECTOR