

**NOTES:**  
**1.MATERIAL SPECIFICATION:**  
 1-1.HOUSING:High-Temp Plastics,UL94V-0,Color:Black.  
 1-2.CONTACTS:Copper Alloy T=0.25mm.  
 1-3.OUTER SHELL:Stainless Steel,T=0.30mm.  
 1-4.INNER SHELL:Stainless Steel,T=0.20mm.  
 1-5.MID-PLATE:Stainless Steel,T=0.20mm.  
 1-6.SOLDER-PLATE:Stainless Steel,T=0.10mm.  
**2.PLATING SPECIFICATION:**  
 2-1.CONTACTS: See Part Number  
 2-2.SHELL:  
 NI UNDERPLATED OVER ALL;  
 Gold Flash Plated ON Solder Leg.  
**3.MECHANICAL PERFORMANCE:**  
 3-1.MATING FORCE:6~20N (Initial);5~20N (After)  
 3-2.UNMATING FORCE:8~20N (Initial);6~20N (After)  
 3-3.DURABILITY:10000 CYCLES.  
**4.ELECTRICAL PERFORMANCE:**  
 4-1.CURRENT RATING:3A/VOLTAGE RATING:5.0V  
 4-2.LLCCR:  
 VBUS & GND PINS:40mA/PIN MAX.;  
 OTHERS PINS:40mA/PIN MAX.;  
 LLCCR MAX. CHANGE OF ALL PINS:10mA.  
 4-3.INSULATION RESISTANCE:100MΩ MIN.  
 4-4.DIELECTRIC WITHSTANDING VOLTAGE:  
 100V AC FOR 1 MINUTE.  
**5.ENVIRONMENTAL PERFORMANCE:**  
 OPERATING TEMPERATURE:-20℃~+85℃.  
**6.RECOMMENDED PROCESS:**  
 THE PEAK TEMPERATURE ON THE BOARD  
 SHALL MAINTAIN 10±1 SECONDS AT 260±5℃.

### Ordering Information

C UZD197 - 16 XX A 001 D X 9 X

Standard Plating  
 05=Gold Flash/Tin  
 Selective Plating  
 02=Gold Flash

Color  
 1=Black

Standard Packing  
 D=Tape&Reel  
 Selective Packing  
 H=Mylar+Tape&Reel



3RD.ANG  
 PROJ.  
  
 PAGE. 1/2

GENERAL TOLERANCE	
X' ±5.0'	X. ±0.30
.X' ±3.0'	.X ±0.25
.XX' ±2.0'	.XX ±0.20
.XXX' ±1.0'	.XXX ±0.15

DESIGNED:

DATE:

CHECKED:

DATE:

APPROVED:

DATE:

DWG. NO.

CUZD197-CA001

PART NO.

CUZD197-16XXA001DX9X

TITLE.

USB Type-C 母 16pin 沉板 1.18 防水型 (外脚 0.80)

REV. A UNIT. mm SCALE. 1:1



## 建议密封方式

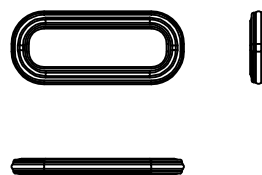
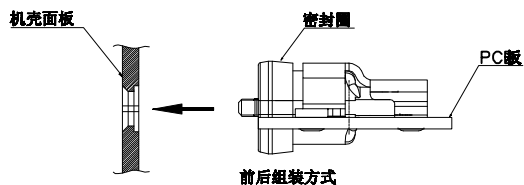

防水圈材质 (硅橡胶)

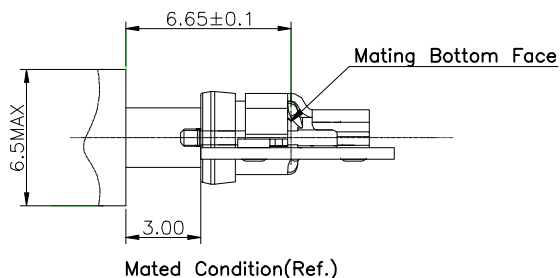

Mated Condition(Ref.)

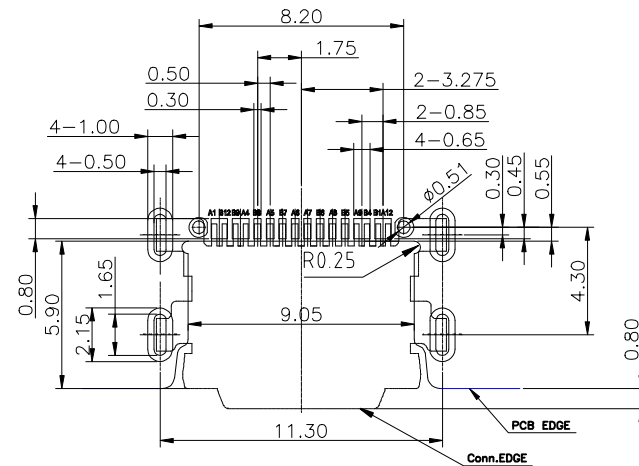

RECOMMENDED PCB LAYOUT  
TOLERANCE:±0.05



Website: www.greenconn.com  
E-mail: sales@greenconn.com

REV. A UNIT. mm SCALE. 1:1

3RD.ANG  
PROJ.  
PAGE. 2/2

GENERAL TOLERANCE	
X'±5.0'	X±0.30
.X'±3.0'	.X±0.25
.XX'±2.0'	.XX±0.20
.XXX'±1.0'	.XXX±0.15

DESIGNED:

DATE:

CHECKED:

DATE:

APPROVED:

DATE:

DWG. NO.

CUZD197-CA001

PART NO.

CUZD197-16XXA001DX9X

TITLE.

USB Type-C每16pin沉板1.18防水型(外翻0.80)