

1 2 3 4 5 6 7 8 9

F
E
D
C
B
A

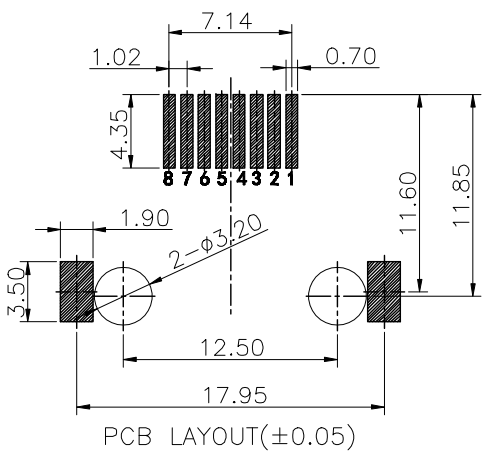
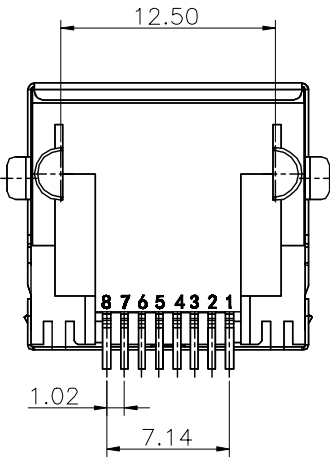
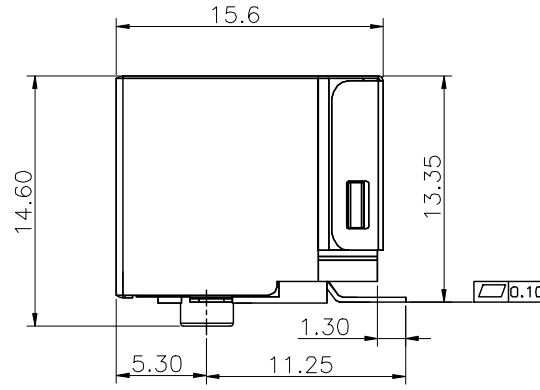
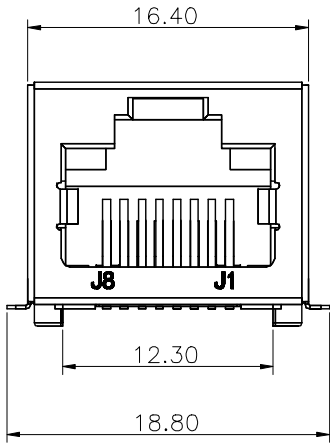

MATERIAL:
 HOUSING: LCP,UL94V-0,BLACK
 TERMINAL: PHOSPHOR BRONZE
 SHIELD: C2680
 MACHANICAL:
 DURABILITY: 750 CYCLES MIN,12.5MM/MINUTE
 INSERTION FORCE: 2.2KG.F MAX
 RETENTION STRENGTH: 7.7KG.F BETWEEN JACK AND PLUG
 OPERATING TEMPERATURE: -40°C~+85°C
 STORAGE TEMPERATURE: -40°C~+85°C.
 ELECTRICAL:
 VOLTAGE: 125 VOLTS AC
 CURRENT RATING:1.5AMP
 DIELECTRIC STRENGTH:1000 VAC RMS 50HZ OR 60HZ,1 MIN
 INSULATION RESISTANCE: 500 MEGA OHMS MIN. INITIAL 500V DC FOR 1 MINUTE
 CONTACT RESISTANCE: SINGLE TERMINAL 30 MILLIOHMS MAX.INITIAL 50 MILLIOHMS MAX. AFTER DURABILITY TEST.
 All materials must meet GREENCONN hazardous substances control standards.

Ordering Information

C TZD110 - 08 XX B 001 C X S X
 Standard Plating 05=Gold Flash/Tin
 Color 1=Black
 Standard Packing D=Tape&Reel

格稜股份有限公司
Greenconn Corporation

REV. 01 UNIT. mm SCALE. 1:1 PAGE. 1/1

GENERAL TOLERANCE	
X.±3.0'	X.±0.35
.X'±2.0'	.X±0.30
.XX'±1.5'	.XX±0.25
.XXX'±1.0'	.XXX±0.10

DESIGNED: _____ DATE: _____
 CHECKED: _____ DATE: _____
 APPROVED: _____ DATE: _____

DWG. NO. CTZD110-CB1CS
 PART NO. CTZD110-08XXB001CX SX

TITLE. RJ 45 直通 56带屏蔽 无灯

1 2 3 4 5 6 7 8 9