

1 2 3 4 5 6 7 8 9

F  
E  
D  
C  
B  
A

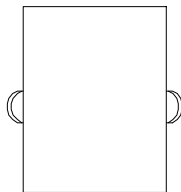

TOP VIEW

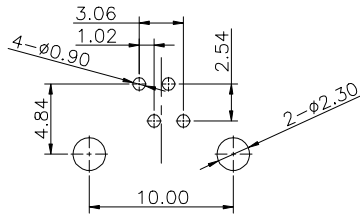

PCB LAYOUT(±0.05)

MATERIAL:  
 HOUSING: PBT,UL94V-0,BLACK  
 TERMINAL: PHOSPHOR BRONZE  
 MACHANICAL:  
 DURABILITY: 750 CYCLES MIN,12.5MM/MINUTE.  
 INSERTION FORCE: 2.2KG.F MAX  
 RETENTION STRENGTH: 7.7KG.F BETWEEN JACK AND PLUG  
 OPERATING TEMPERATURE: -40°C~+85°C  
 STORAGE TEMPERATURE: -40°C~+85°C.  
 ELECTRICAL:  
 VOLTAGE: 125 VOLTS AC  
 CURRENT RATING:1.5AMP  
 DIELECTRIC STRENGTH:1000 VAC RMS 50HZ OR 60HZ,1 MIN  
 INSULATION RESISTANCE: 500 MEGA OHMS MIN. INITIAL 500V DC FOR 1 MINUTE  
 CONTACT RESISTANCE: SINGLE TERMINAL 30 MILLIOHMS MAX.INITIAL 50 MILLIOHMS MAX. AFTER DURABILITY TEST.  
 All materials must meet GREENCONN hazardous substances control standards.

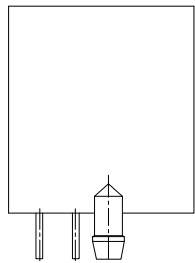

LEFT SIDE VIEW

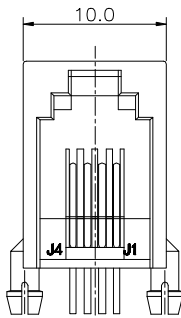

FRONT VIEW

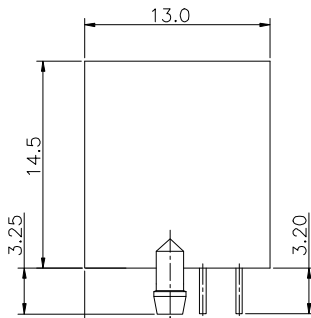

RIGHT SIDE VIEW

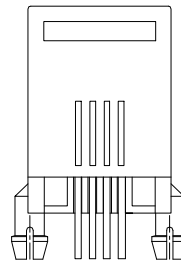

BACK VIEW

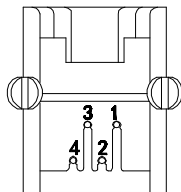

BOTTOM VIEW

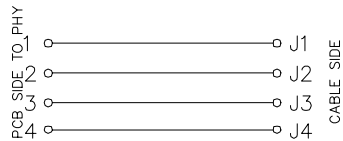

### Ordering Information

C TZB124 - 04 XX B 001 A X S X

Standard Plating  
02=Gold Flash

Color  
1=Black

Standard Packing  
B=Tray  
Selective Packing  
N=PE Bag

格稜股份有限公司  
**Greenconn Corporation**

GENERAL TOLERANCE

X.'±3.0'	X.±0.35
.X'±2.0'	.X±0.30
.XX'±1.5'	.XX±0.25
.XXX'±1.0'	.XXX±0.10

DESIGNED:	DATE:
CHECKED:	DATE:
APPROVED:	DATE:

DWG. NO. CTZB124-CB1AS
PART NO. CTZB124-04XXB001AXSX

TITLE. RJ11 4P4C 无灯全塑
--------------------------

REV. A	UNIT. mm	SCALE. 1:1	PAGE. 1/1	
--------	----------	------------	-----------	--

1 2 3 4 5 6 7 8 9